



Electricity Class 10 Important Questions Very Short Answer Type

Question 1.

Write the relation between electric power (P) of a device with potential difference (Volt) across it and current (amp) flowing through it. (2013)

Answer:

The power (P) in watts is found by multiplying the potential difference (V) in volts by the current (I) in amperes.

Electric power = Potential difference \times Current

$$\therefore P = V \times I$$

Question 2.

A charge of 150 coulomb flows through a wire in one minute. Find the electric current flowing through it. (2014)

Answer:

Charge, $Q = 150 \text{ C}$; Time, $t = 1 \text{ min} = 60 \text{ s}$

Current, $I = Q / t = 150 / 60 = 2.5 \text{ Amp}$

Question 3.

A voltmeter is to be connected in the circuit to measure potential difference across a conductor. Mention the type of combination in which it should be connected with the conductor. (2014)

Answer:

The voltmeter is always connected in parallel across the conductor.

Question 4.

Out of the three wires live, neutral or earth, which one goes through ON/OFF switch? (2015)

Answer:

The live wire goes through ON/OFF switch.

Question 5.

What is the shape of the graph between V and I, where V is the potential difference applied between the ends of a wire and I is the current flowing through it? (2015)

Answer:

The graph between the potential difference (V) and the corresponding current (I) is a straight line passing through the origin.

Short Answer Type I

Question 1.

An electric heater rated 800 W operates 6h/day. Find the cost of energy to operate it for 30 days at ₹3.00 per unit. (2012)



Answer:

Power of the heater, $P = 800 \text{ W}$; Time, $t = 6 \text{ hour/day}$; No. of days, $n = 30$;

Cost per unit = ₹3.00; Total cost of its usage = ?; Energy, $E = P \times t$

Consumed in 1 day = $800 \times 6 = 4800 \text{ Wh}$

Energy consumed in 30 days = $4800 \times 30 = 144000 \text{ Wh}$

$144000 / 1000 \text{ kWh} = 144 \text{ units}$

Cost of 1 unit = ₹3

\therefore Cost of 144 units = $3 \times 144 = ₹432$

Question 2.

Explain two disadvantages of series arrangement for household circuit. (2012)

Answer:

Disadvantages of series circuits for domestic wiring:

1. In series circuit, if one electrical appliance stops working due to some defect then all other appliances also stop working because the whole circuit is broken.
2. In series circuit, all the electrical appliances have only one switch due to which they cannot be turned off or turned on separately.

Question 3.

Three resistors of 10Ω , 15Ω and 5Ω are connected in parallel. Find their equivalent resistance. (2013)

Answer:

$R_1 = 10 \Omega$, $R_2 = 15 \Omega$, $R_3 = 5 \Omega$

R_1 , R_2 and R_3 are connected in parallel then equivalent resistance (R) is given by

$$\frac{1}{R} = \frac{1}{R_1} + \frac{1}{R_2} + \frac{1}{R_3} \quad \Rightarrow \quad \frac{1}{R} = \frac{1}{10} + \frac{1}{15} + \frac{1}{5} = \frac{3+2+6}{30} = \frac{11}{30}$$

\therefore Equivalent resistance, $R = 30 / 11 = 2.72 \Omega$

Question 4.

Give two reasons why different electrical appliances in a domestic circuit are connected in parallel. (2013)

Answer:

The arrangement of lights and various other electrical appliances in parallel circuits is used in domestic wiring because of following advantages:

1. In parallel circuits, if one electrical appliance stops working due to some defect, then all other appliances keep working normally.
2. In parallel circuits, each electrical appliance has its own switch due to which it can be turned on or turned off independently, without affecting other appliances.



Question 5.

- (a) What is least count of voltmeter?
 (b) In a voltmeter there are 20 divisions between the '0' mark and 0.5 V mark. Calculate its least count. (2017 OD)

Answer:

(a) The minimum potential difference measured by a voltmeter between the two given terminals is called the least count of that voltmeter.

(b) Two given marks of the voltmeters = 0 and 0.5 V

Potential difference = $0.5 - 0 = 0.5\text{V}$

No. of divisions between these two marks = 20

$$\text{Least count} = \frac{0.5}{20} = \frac{5}{20 \times 10} = \frac{1}{40} = 0.025 \text{ volts}$$

Short Answer Type II

Question 1.

(a) Nichrome wire of length 'l' and radius 'r' has resistance of 10Ω . How would the resistance of the wire change when:

- (i) Only length of the wire is doubled?
 (ii) Only diameter of the wire is doubled? Justify your answer.

(b) Why element of electrical heating devices are made up of alloys? (2012)

Answer:

(a) Resistance, $R \propto l$

$$R \propto l/A \Rightarrow R \propto l/A$$

$$R = 10\Omega \text{ (or) } R = \rho l/A$$

(i) Resistance is directly proportional to the length of the conductor. If length of nichrome wire (l) is doubled its resistance also gets doubled.

$$\therefore R', \text{ new resistance} = 20 \Omega$$

(ii) The resistance of the wire is inversely proportional to the square of its diameter. If the diameter of the wire is doubled, its resistance becomes one-fourth.

$$\therefore R', \text{ new resistance} = 104 \Omega = 2.5 \Omega$$

(b) The heating elements of electrical heating appliances are made up of nichrome alloy because:

- Nichrome has very high resistivity due to which it produces a lot of heat on passing current.
- Nichrome does not undergo oxidation easily even at high temperature, it can be kept red hot without burning.

Question 2.

Three resistors of 5Ω , 10Ω and 15Ω are connected in series and the combination is connected to battery of 30 V . Ammeter and Voltmeter are connected in the circuit.



Draw a circuit diagram to connect all the devices in proper correct order. What is the current flowing and potential difference across $10\ \Omega$ resistance? (2012)

Answer:

Current flowing, $I = ?$, $V_2 = ?$

Total resistance, $R = R_1 + R_2 + R_3 = 5 + 10 + 15 = 30\ \Omega$

Total potential difference, $V = 30$

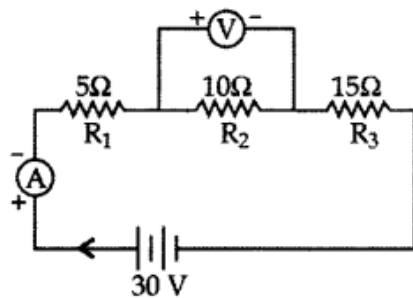

volts According to Ohm's law,

$$V = IR \Rightarrow I = \frac{V}{R} = \frac{30}{30} = 1 \text{ amp}$$

\therefore Current remains constant in series,

$\therefore I_1 = I_2 = I_3 = I$; $I_2 = 1 \text{ amp}$; $R_2 = 10\ \Omega$; $V_2 = ?$

As $V_2 = I_2 R_2 = 1 \times 10 = 10 \text{ volts}$

\therefore Potential difference across $10\ \Omega$ is 10 volts.

Question 3.

What is meant by overloading of an electrical circuit? Explain two possible causes due to which overloading may occur in household circuit? Explain one precaution that should be taken to avoid the overloading of domestic electric circuit. (2012)

Answer:

Overloading: The current flowing in domestic wiring at a particular time depends on the power ratings of the appliances being used. If too many electrical appliances of high power rating are switched on at the same time, they draw extremely large quantity of current from the circuit. This is known as the overloading of the circuit. Due to large current flowing through the wires of the household circuits, their copper wires get heated up to a very high temperature and can cause a fire.

Precaution: Thus, overloading can be highly damaging to electrical appliances and buildings. So, fuse of proper rating must be used to avoid such damages. Such a fuse-wire will melt before the temperature of the heated circuit wire becomes too high and causes the circuit to break.

Question 4.

An electric iron consumes energy at a rate of 840 W when heating is at the

maximum and 360 W when the heating is at the minimum. The voltage at which it is running is 220 V. What are the current and resistance in each case? (2012)

Answer:

At maximum heating:

The consumption of energy (electric) is given at the rate of 840 W at Voltage 220 V.

∴ $P = 840 \text{ W}$, $V = 220 \text{ V}$, then Current, $I_1 = ?$

∴ $P = V \times I_1$

$$I_1 = \frac{P}{V} = \frac{840}{220} = 3.81 \text{ A}$$

Resistance, $R_1 = ?$

∴ $V = I_1 R_1$

$$\Rightarrow R_1 = \frac{V}{I_1} = \frac{220}{3.81} \Rightarrow R_1 = \frac{V}{I_1} = \frac{220^{110}}{42^{21}} \times 11 = \frac{1210}{21} = 57.6 \Omega$$

At minimum temperature:

$V = 220 \text{ Volts}$, $P = 360 \text{ W}$, then Current, $I_2 = ?$

∴ $P = V \times I_2$

$$I_2 = \frac{P}{V} = \frac{360}{220} = 1.6 \text{ A}$$

Resistance, $R_2 = ?$

∴ $V = I_2 R_2$

$$R_2 = \frac{V}{I_2} = \frac{220}{1.6} \Rightarrow R_2 = \frac{220^{110}}{18^9} \times 11 = \frac{1210}{9} = 134.4 \Omega$$

Question 5.

Give reason for the following:

(i) Electric bulbs are usually filled with chemically inactive gases like nitrogen and argon.

(ii) Copper and aluminium wires are usually employed for electricity transmission.

(iii) Fuse wire is placed in series with the device. (2012)

Answer:

(i) Electric bulbs are usually filled with chemically inactive gases like nitrogen and argon because these gases do not react with the hot tungsten filament and hence prolong the life of filament of the electric bulb.

(ii) Copper and aluminium wires are usually employed for electricity transmission because copper and aluminium have very low resistivity and thus they are very good conductors of electricity.

(iii) Fuse wire is placed in series with the device because when large current passes through the circuit the fuse wire gets heated up and melts and whole circuit breaks and the device is protected from the damage.

Question 6.

(i) Calculate the current through a lamp of 25 W operating at 250 V.

(ii) Why elements of electrical heating devices are made up of alloys? (2013)

Answer:

(i) Power of the lamp, $P = 25 \text{ W}$

Potential difference, $V = 250 \text{ V}$ Current, $I = ?$

Formula: $P = V \times I \therefore 25 = 250 \times I$

\therefore Current, $I = 25 / 250 = 1 / 10 = 0.1 \text{ A}$

(ii) The heating elements of electrical heating appliances are made up of nichrome alloy because:

- Nichrome has very high resistivity due to which it produces a lot of heat on passing current.
- Nichrome does not undergo oxidation easily even at high temperature, it can be kept red hot without burning.

Question 7.

Find the resistance between points A and B in the circuit diagram given below: (2013)

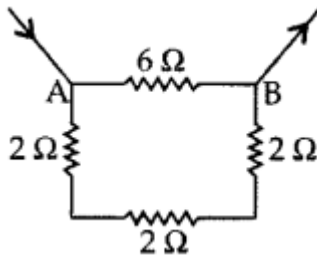

Solution:

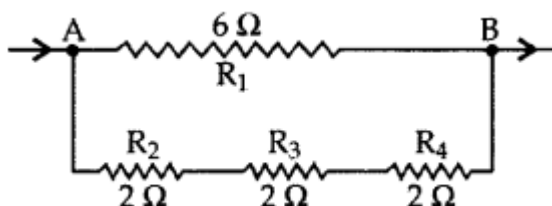
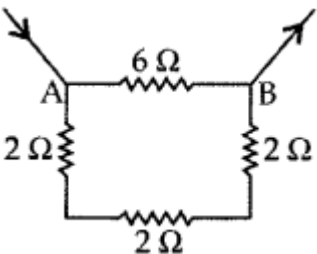



R_2, R_3, R_4 are in series and have resultant resistance R'

$R_1 = 6\Omega$;

R' is in parallel combination with R_1 .

\therefore Resultant resistance of the circuit (R)

$$\Rightarrow \frac{1}{R} = \frac{1}{R_1} + \frac{1}{R_1} = \frac{1}{6} + \frac{1}{6} = \frac{2}{6} = \frac{1}{3}$$

\therefore Resistance $R = 3\Omega$

Question 8.

A bulb is rated at 200 V, 100 W. Calculate its resistance. Five such bulbs burn for 4 hours daily. Calculate the units of electrical energy consumed per day. What would be the cost of using these bulbs per day at the rate of ₹4.00 per unit? (2013)

Solution:

$P = 100 \text{ W}, V = 200 \text{ V}, R = ?$

$$P = \frac{V^2}{R} \quad \Rightarrow \quad R = \frac{V^2}{P}$$

$$\Rightarrow R = \frac{(200)^2}{100} \quad \therefore \quad R = \frac{200 \times 200}{100} = 400 \Omega$$

Given $P = 100 / 1000 \text{ kW}$; Time, $t = 4$ hours

Electrical energy consumed, $E = P \times t$

Energy consumed by 1 bulb = $0.1 \times 4 = 0.4 \text{ kWh}$

\therefore Energy consumed by 5 bulbs = $5 \times 0.4 = 2 \text{ kWh} = 2$ units

Cost of electrical energy:

Cost of 1 unit of electricity = ₹4

\therefore Cost of 2 units of electricity = $4 \times 2 = ₹8$

Question 9.

(a) Draw the nature of $V - I$ graph for a nichrome wire. (V – Potential difference, I – Current)

(b) A metallic wire of 625 mm length offers a 4Ω resistance. If the resistivity of the metal is 4.8×10^{-7} ohm-metre then calculate the area of cross-section of the wire.

(2013)

Answer:

(a)

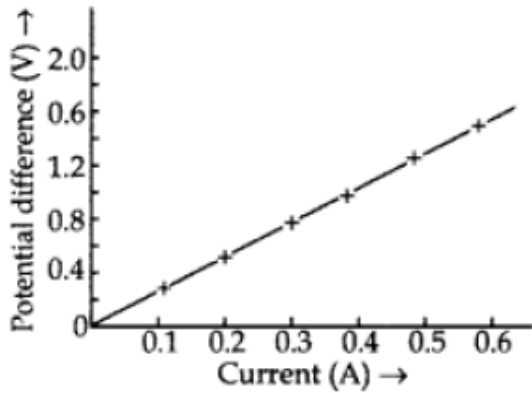

V-I graph for a nichrome wire

A straight line plot shows that as the current through a wire increases, the potential difference across the wire increases. This is Ohm's law.

(b) Resistivity, $\rho = (R \times A) / l$

Where

[R = Resistance of the conductor

A = Area of cross-section of conductor

l = Length of the conductor]

$\rho = 4.8 \times 10^{-7} \Omega\text{m}$, $R = 4\Omega$

$$l = 625 \text{ mm} = \frac{625}{10 \times 100} \text{ m} = 0.625 \text{ m}$$

$$\therefore \text{Area, } A = \frac{\rho l}{R} = \frac{4.8 \times 10^{-7} \times 0.625}{4} = 0.75 \times 10^{-7} \text{ m}^2 = 7.5 \times 10^{-8} \text{ m}^2$$

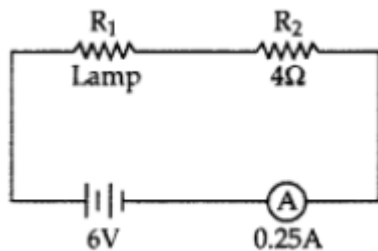

Question 10.

An electric lamp and a conductor of resistance 4Ω are connected in series to a 6 V battery. The current drawn by the lamp is 0.25A . Find the resistance of the electric lamp. (2013)

Answer:

Lamp: Resistance, $R_1 = ?$

Potential difference, $V_1 = ?$;

Current drawn, $I_1 = 0.25\text{A}$



Other conductor:

Resistance, $R_2 = 4\Omega$; Potential difference, $V_2 = ?$; Current drawn, $I_2 = ?$

Resultant resistance, $R = R_1 + R_2$ [\because The two resistances are connected in series]

\therefore Potential difference, $V = 6V$

Current in the circuit, $I = 0.25 A$

$\therefore I = I_1 = I_2$ [In series combination]

$\therefore V = IR$ [By Ohm's law]

$$\Rightarrow R = \frac{V}{I} = \frac{6}{0.25} = \frac{6 \times 100}{25} = 24 \Omega$$

Now $R_1 + R_2 = R \Rightarrow R_1 + 4 = 24$

$\therefore R_1 = 24 - 4 = 20 \Omega$

Question 11.

A circuit has a line of 5 A. How many lamps of rating 40W; 220V can simultaneously run on this line safely? 2014

Answer:

$I = 5A$; No. of lamps = n ; Power, $P = 40 W$; $V = 220V$

Power of 1 bulb = 40 W, Power of n bulbs = 40 n watts

$P = V \times I$

$40n = 220 \times 5 \Rightarrow n = (220 \times 5) / 40 = 55 / 2 = 27.5$

\therefore No. of lamps = 27

Question 12.

The resistance of a wire of 0.01 cm radius is 10 Ω . If the resistivity of the material of the wire is 50×10^{-8} ohm meter, find the length of the wire. (2014)

Answer:

Resistance of a wire, $R = 10 \Omega$

Radius, $r = 0.01 \text{ cm} = 0.01 \times 10^{-2} \text{ m}$

Resistivity, $S = 50 \times 10^{-8}$ ohm meter

Length of the wire, $l = ?$

Area of cross section, $A = \pi r^2 = 3.14 \times (0.01 \times 10^{-2})^2 \text{ m}^2$

$= 3.14 \times 0.01 \times 0.01 \times 10^{-4} \text{ m}^2$

$= 3.14 \times 10^{-8} \text{ m}^2$

$$S = \frac{R \times A}{l}$$

$$l = \frac{R \times A}{S} = \frac{10 \times 3.14 \times 10^{-8}}{50 \times 10^{-8}} = \frac{3.14}{5} \text{ m} = \frac{314}{500} \text{ m} = 0.628 \text{ m}$$

Question 13.

Show four different ways in which four resistors of r ohm each may be connected in a circuit. In which case is the equivalent resistance of the combination (2014)

(i) maximum; (ii) minimum?

Answer:

(a)

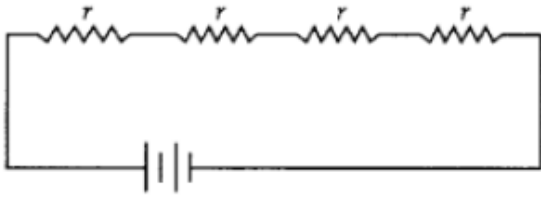

Resultant resistance = $R = r + r + r + r$; $R = 4r$

(b)

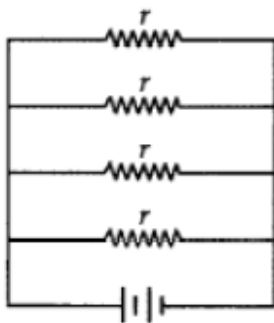

$$\frac{1}{R} = \frac{1}{r} + \frac{1}{r} + \frac{1}{r} + \frac{1}{r} = \frac{4}{r} = R = \frac{r}{4}$$

(c)

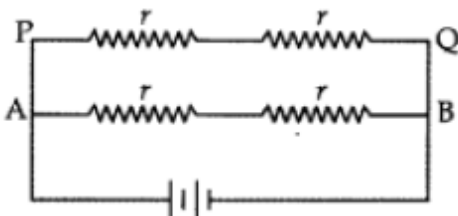

Resistance (AB) = $R_1 = r + r = 2r$

Resistance (PQ) = $R_2 = r + r = 2r$

Resultant, $R = ?$

$$\frac{1}{R} = \frac{1}{R_1} + \frac{1}{R_2} = \frac{1}{2r} + \frac{1}{2r} = \frac{1+1}{2r} = \frac{2}{2r} = \frac{1}{r}$$

$$R = r$$

(d)

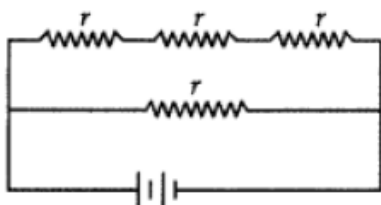



$$R_1 = r + r + r = 3r$$

Resultant, $R = ?$

$$\frac{1}{R} = \frac{1}{R_1} + \frac{1}{r} = \frac{1}{3r} + \frac{1}{r} = \frac{1+3}{3r} = \frac{4}{3r}$$

$$R = \frac{3r}{4}$$

- (i) Maximum resistance = Case (a) where all the resistors are combined in series.
- (ii) Minimum resistance = Case (b) where all the resistors are combined in parallel combination.

Question 14.

Amit lives in Delhi and is much concerned about the increasing electricity bill of his house. He took some steps to save electricity and succeeded in doing so. (2014)

- (i) Amit fulfilled his duty towards the environment by saving electricity. How?
- (ii) Which alternative source of energy would you suggest Amit to use?

Answer:

- (i) By saving electricity, Amit is contributing in his small way towards reducing environmental degradation. Most of the electrical appliances use electrical energy which is generated by burning fossil fuel. The burning of fossil fuels causes air pollution. The production of hydroelectricity causes ecological imbalance. Therefore, by using less electricity he is indirectly causing less pollution.
- (ii) He can use solar energy devices like solar cooker, solar water heater and solar cells.

Question 15.

An electric iron draws 2.2 amperes of current from a 220 V source. Find its (i) resistance and (ii) wattage (Power). (2014)

Answer:

Current drawn, $I = 2.2$ amp; Potential difference, $V = 220$ V

Resistance, $R = ?$; Power, $P = ?$

According to ohm's law:

$$V = IR$$

$$R = \frac{V}{I} = \frac{220}{2.2} = \frac{220}{22} \times 10 = 100 \Omega$$

$$\Rightarrow p = v \times I = 220 \times 2.2 = 484 \text{ W}$$

Question 16.

Define 1 ohm resistance. (2014)

A student has a resistance wire of 1 ohm. If the length of this wire is 50 cm, to what length he should stretch it uniformly so as to obtain a wire of 4 Ω resistance? Justify



your answer.

Answer:

1 ohm is the resistance of a conductor such that when a potential difference of 1 volt is applied to its ends, a current of 1 ampere flows through it.

Resistance, $R_1 = 1 \Omega$;

$L_1 = 50 \text{ cm} = 50 / 100\text{m} = 1 / 2\text{m}$

Required resistance, $R_2 = 4 \Omega$; Required length, $L_2 = ?$

$R \propto L$

$$\frac{R_1}{L_1} = \text{Constant}, \frac{R_2}{L_2} = \text{Constant}$$

$$\frac{R_1}{L_1} = \frac{R_2}{L_2} = \frac{1}{1/2} = \frac{4}{L_2} \quad \Rightarrow \quad \frac{1 \times 2}{1} = \frac{4}{L_2}$$

$$L_2 = \frac{4}{2} \quad \therefore \quad L_2 = 2\text{m}$$

Question 17.

Define an electric circuit. Draw a labelled, schematic diagram of an electric circuit comprising of a cell, a resistor, an ammeter, a volt meter and a closed switch. (2015)

Answer:

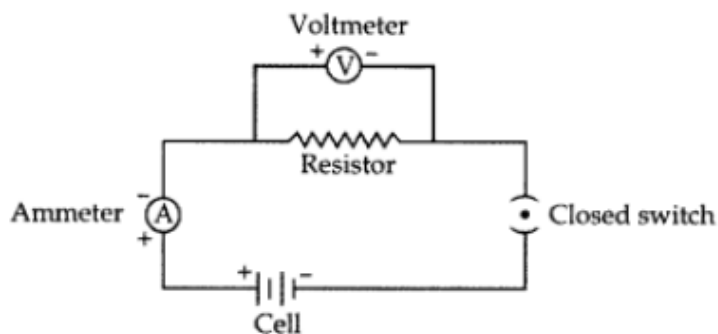

Schematic diagram of electric circuit

Electric circuit. A continuous conduction path consisting of wires and other resistances (like bulb, fan, etc.) and a switch between the two terminals of a cell or a battery along which an electric current flows, is called a circuit.

Question 18.

Find the current drawn from the battery by the network of four resistors shown in the figure. (2015)

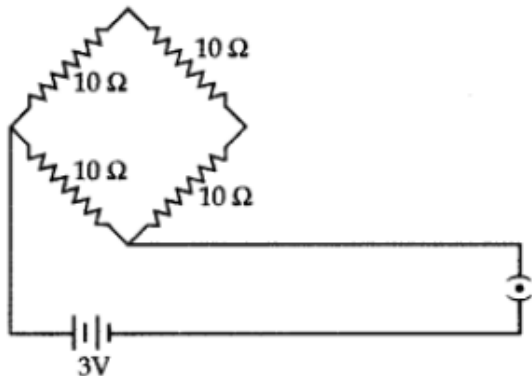

Answer:

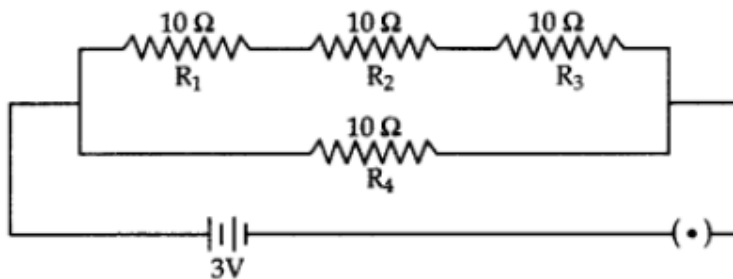

Resultant resistance of R_1 , R_2 and R_3 : $R' = R_1 + R_2 + R_3 = 10 + 10 + 10 = 30\Omega$

Resultant resistance of the circuit R : $\frac{1}{R} = \frac{1}{R'} + \frac{1}{R_4} = \frac{1}{30} + \frac{1}{10} = \frac{1+3}{30} = \frac{4}{30}$

$$R = \frac{30}{4} = \frac{15}{2} = 7.5 \Omega$$

$$V = 3 \text{ volts}$$

$$V = IR$$

$$I = ?$$

$$\Rightarrow I = \frac{V}{R} = \frac{3}{7.5} = \frac{30}{75} = 0.4 \text{ A}$$

Question 19.

Two lamps, one rated 40W at 220V and the other 100 W at 220V, are connected in parallel to the electric supply at 220V. (2017 D)

(a) Draw a circuit diagram to show the connections.

(b) Calculate the current drawn from the electric supply.

(c) Calculate the total energy consumed by the two lamps together when they operate for one hour.

Answer:



(a)

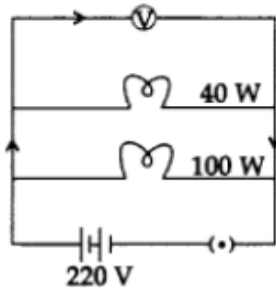

(b) $P_1 = 40 \text{ W}, \quad V_1 = 220\text{V}, \quad I_1 = ?$

$$I_1 = \frac{P_1}{V_1} = \frac{40}{220} = \frac{2}{11} \text{ ampere}$$

$P_2 = 100 \text{ W}, \quad V_2 = 220\text{V}, \quad I_2 = ?$

$$I_2 = \frac{P_2}{V_2} = \frac{100}{220} = \frac{5}{11} \text{ ampere}$$

Total current drawn, $I = I_1 + I_2 = \frac{2}{11} + \frac{5}{11} = \frac{7}{11} \text{ ampere}$

(c) $E_1 = P_1 \times t$

$$= 40 \times 1 = 40 \text{ Wh}$$

$E_2 = P_2 \times t$

$$= 100 \times 1 = 100 \text{ Wh}$$

Total energy consumed = $40 \text{ Wh} + 100 \text{ Wh} = 140 \text{ Wh} = \frac{140}{1000} \text{ kWh} = 0.14 \text{ kWh}$

Question 20.

Two resistors, with resistance 10Ω and 15Ω , are to be connected to a battery of e.m.f. 12 V so as to obtain: (2017 D)

(i) minimum current (ii) maximum current

(a) Describe the mode of connecting the resistances in each case.

(b) Calculate the strength of the total current in the circuit in each case.

Answer:

(i) Resistances are connected in series to obtain minimum current

$$R_1 = 10 \Omega, \quad R_2 = 15 \Omega, \quad \text{Voltage} = 12 \text{ V}$$

$$\text{Resultant, } R = R_1 + R_2 = 10 + 15 = 25 \Omega$$

$$\text{Potential difference, } V = 12 \text{ V}, \quad I = ?$$

According to Ohm's Law:

$$V = IR$$

$$I = \frac{V}{R} = \frac{12}{25} = 0.48 \text{ A}$$

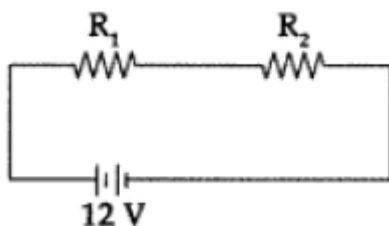

(ii) The resistances are connected in parallel to obtain maximum current

$$R_1 = 10\Omega, \quad R_2 = 15\Omega, \quad V = 12 \text{ Volts}$$



$$\frac{1}{R} = \frac{1}{R_1} + \frac{1}{R_2} \quad \Rightarrow \quad \frac{1}{R} = \frac{1}{10} + \frac{1}{15} = \frac{3+2}{30} = \frac{5}{30}$$

$$\Rightarrow \frac{1}{R} = \frac{1}{6} \quad \Rightarrow \quad R = 6 \Omega$$

According to Ohm's Law, $V = IR$ $\therefore I = \frac{V}{R} = \frac{12}{6} = 2A$

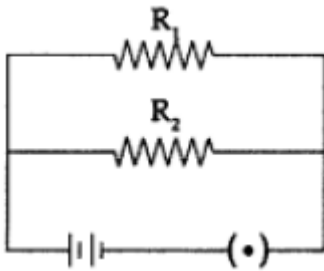

Question 21.

Show how you would connect three resistors, each of 6Ω , so that the combination has a resistance of: (a) 9Ω , (b) 4Ω (2017 OD)

Answer:

Given: $R_1 = R_2 = R_3 = 6 \Omega$

(a) When R_1 is connected in series with the parallel combination of R_2 and R_3 [Fig (a)].

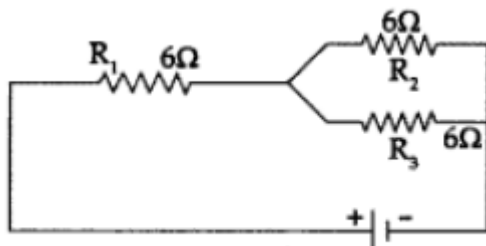

Figure (a)

The equivalent resistance is:

$$R = R_1 + \frac{R_2 R_3}{R_2 + R_3}$$

$$= 6 + \frac{6 \times 6}{6 + 6} = 6 + 3 = 9 \Omega$$



(b) When a series combination of R_1 and R_2 is connected in parallel with R_3 [Fig (b)].

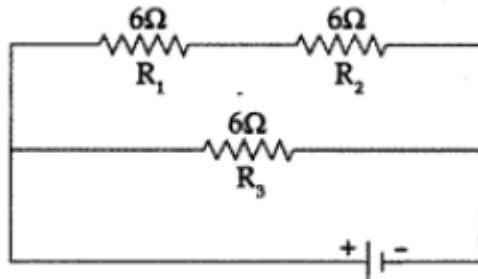

Figure (b)

The equivalent resistance is:

$$R = (12 \times 6) / (12 + 6) = 72 / 18 = 4 \Omega$$

Long Answer Type

Question 1.

(a) Calculate the resistance of the wire using the graph.

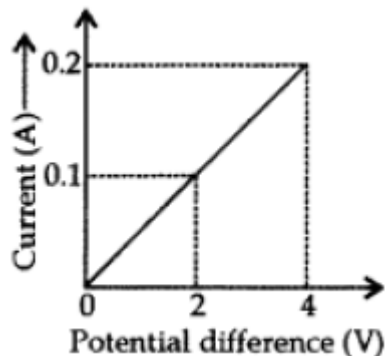

(b) How many 176Ω resistors in parallel are required to carry 5 A on a 220 V line?

(c) Define electric power. Derive relation between power, potential difference and resistance. (2012)

Answer:

(a) Resistance of wire = Slope of the graph

According to Ohm's law,

$$V = IR \text{ (or) } R = V/I$$

$$\therefore R = \frac{V_2 - V_1}{I_2 - I_1} = \frac{4 - 2}{0.2 - 0.1} = \frac{2 \times 10}{1} = 20 \Omega$$

(b) Resistance, $R' = 176 \Omega$,

Potential difference, $V = 220$ volts,

No of resistors = n ,

Current, $I = 5A$

Resultant resistance = R



According to Ohm's law,

$$V = IR \quad \Rightarrow \quad R = \frac{V}{I} = \frac{220}{5} = 44 \, \Omega$$

$$\frac{1}{R} = \left(\frac{1}{R'} + \frac{1}{R'} + \dots n \text{ times} \right) = \frac{1+1+1+\dots n \text{ times}}{R'}$$

$$\frac{1}{R} = \frac{n}{R'} \quad \Rightarrow \quad n = \frac{R'}{R} = \frac{176}{44} = 4$$

Thus 4 resistors of $176 \, \Omega$ in parallel combination are required to carry 5 A on a 220 V line.

(c) Electric power is defined as the electrical work done per unit-time.

Power = Work done / Time taken

$$\Rightarrow P = \frac{W}{t}$$

The work done, W by current, I when it flows for time t under potential difference V is given by $W = V \times I \times t$ joules

$$\therefore P = \frac{W}{t} \quad \therefore P = \frac{V \times I \times t}{t} \quad \therefore P = V \times I$$

$$\text{But } I = \frac{V}{R}$$

$$\text{So, } P = \frac{V \times V}{R} \quad \Rightarrow \quad P = \frac{V^2}{R}$$

$$\text{Electric power} = \frac{(\text{Potential difference})^2}{\text{Resistance}}$$

Question 2.

(a) Resistors given as R_1 , R_2 and R_3 are connected in series to a battery V . Draw the circuit diagram showing the arrangement. Derive an expression for the equivalent resistance of the combination.

(b) If $R_1 = 10 \, \Omega$, $R_2 = 20 \, \Omega$ and $R_3 = 30 \, \Omega$, calculate the effective resistance when they are connected in series to a battery of 6 V. Also find the current flowing in the circuit. (2012)

Answer:

(a) Same current (I) flows through different resistances, when these are joined in series, as shown in the figure:

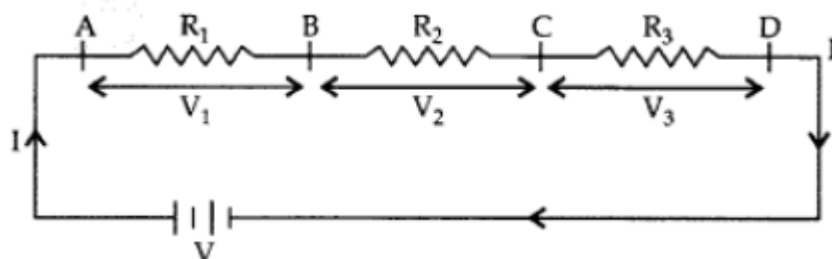

Let R be the combined resistance, then, $V = IR$

$$V_1 = IR_1, \quad V_2 = IR_2, \quad V_3 = IR_3$$

$$\therefore V = V_1 + V_2 + V_3$$



$$\therefore IR = IR_1 + IR_2 + IR_3 \Rightarrow IR = I(R_1 + R_2 + R_3)$$

$$\therefore R = R_1 + R_2 + R_3$$

(b) $R_1 = 10 \Omega$, $R_2 = 20 \Omega$, $R_3 = 30 \Omega$
 Effective resistance, $R = R_1 + R_2 + R_3$
 $R = 10 + 20 + 30 = 60 \Omega$
 Potential difference, $V = 6V$,
 Current, $I = ?$

According to Ohm's law,

$$V = IR \quad \Rightarrow \quad I = \frac{V}{R} = \frac{6}{60} = 0.1 \text{ A}$$

Question 3.

- (a) Define electric resistance of a conductor.
 (b) List two factors on which resistance of a conductor depends.
 (c) Resistance of a metal wire of length 1 m is 104Ω at 20°C . If the diameter of the wire is 0.15 mm, find the resistivity of the metal at that temperature.

Answer:

(a) The property of a conductor due to which it opposes the flow of current through it, is called resistance.

(b) The resistance of a conductor depends on length, thickness, nature of material and temperature of the conductor.

- Long wire (or conductor) has more resistance and a short wire has less resistance.
- A thick wire has less resistance whereas a thin wire has more resistance.

(c) Length of the metal, $l = 1 \text{ m}$
 Resistance, $R = 104 \Omega$
 at temperature, $t = 20^\circ \text{C}$
 Diameter of the wire, $d = 0.15 \text{ mm}$

$$\text{radius, } r = \frac{0.15}{2} \times 10^{-3}$$

$$\text{Formula: Resistivity, } S = \frac{R \times A}{l}$$

$$A = \pi r^2 = \frac{22}{7} \times \frac{0.15}{2} \times \frac{0.15}{2} \times 10^{-6} \text{ m}^2 \quad \therefore \quad A = 176.785 \times 10^{-10} \text{ m}^2$$

$$S = \frac{104 \times 176.785 \times 10^{-10}}{1} = 183.86 \times 10^{-8} \Omega \text{m}$$



Question 4.

- (a) Differentiate between AC and DC. Write any two points of difference.
 (b) A person operates a microwave oven of 2kW power rating in a domestic circuit of 220 V and current rating 5A. What result is expected? Explain with reason.
 (c) Write the frequency of AC and DC. (2013)

Answer:

(a) Differentiate between AC and DC

AC:

- If the current reverses its direction after equal intervals of time, it is called alternating current (AC).
- Some sources of alternating current are power house generators, car alternators and bicycle dynamos.

DC:

- If the current flows in one direction only, it is called direct current (DC).
- Sources of direct current are dry cell, dry cell battery, car battery.

(b) Power of the oven, $P = 2 \text{ kW} = 2000 \text{ W}$;

Potential difference, $V = 220 \text{ volt}$;

Current, $I = 5\text{A}$

$P = V \times I = 220 \times 5 = 1100 \text{ volt, A} = 1100 \text{ W}$

This shows that microwave requires more electrical energy than the energy provided by the circuit. The microwave will not work and fuse wire will break due to overloading.

(c) The AC produced in India has a frequency of 50 Hz, it means the current reverses its direction 100 times in a second.

DC always flows in one direction, it means polarity of direction current is fixed and it has no frequency.

Question 5.

(a) Two identical resistors each of resistance 10 ohm are connected:

(i) in series

(ii) in parallel, in turn to a battery of 6V. Calculate the ratio of power consumed in the combination of resistors in the two cases.

(b) Establish the relationship between 1 kWh and SI unit of energy. (2013)

Answer:

(a) (i) Resultant resistance, $R = R_1 + R_2 = 10 + 10 = 20 \Omega$

$$P_1 = \frac{V^2}{R} = \frac{(6)^2}{20} = \frac{6^3 \times 6^3}{20 \times 10^5} = \frac{9}{5} \quad \dots(i)$$

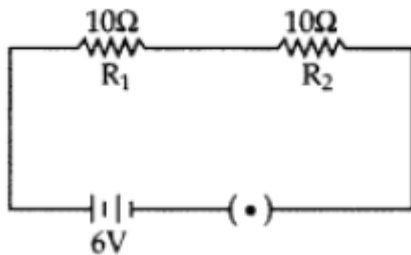

(ii) Resultant resistance, $R = ?$

$$\frac{1}{R} = \frac{1}{R_1} + \frac{1}{R_2} = \frac{1}{10} + \frac{1}{10} = \frac{2}{10} = \frac{1}{5}$$

$$R = 5 \Omega$$

$$P_2 = \frac{V^2}{R} = \frac{(6)^2}{5} = \frac{6 \times 6}{5} = \frac{36}{5} \quad \dots(ii)$$

From (i) and (ii),

$$\frac{P_1}{P_2} = \frac{\frac{9}{5}}{\frac{36}{5}} = \frac{9}{36} = \frac{1}{4}$$

$$\therefore P_1 : P_2 :: 1 : 4$$

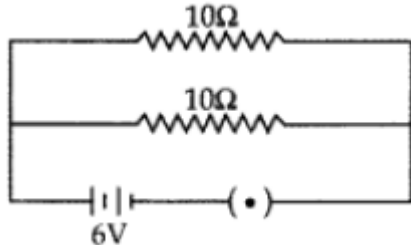

(b) Relation between kilowatt-hour and joule (SI unit of energy):

1 kilowatt-hour is the amount of energy consumed at the rate of 1 kilowatt for 1 hour.

i.e., 1 kilowatt-hour = 1 kilowatt for 1 hour

(or)

1 kilowatt-hour = 1000 watts for 1 hour

$$\text{But } 1 \text{ watt} = \frac{1 \text{ joule}}{1 \text{ second}} \quad \therefore \quad 1 \text{ kilowatt-hour} = \frac{1000 \text{ joules}}{\text{seconds}} \text{ for 1 hour}$$

$$\text{and, } 1 \text{ hour} = 60 \times 60 \text{ seconds} \quad \therefore \quad 1 \text{ kilowatt-hour} = \frac{1000 \text{ joules}}{\text{seconds}} \times 60 \times 60 \text{ seconds}$$

(or)

1 kilowatt-hour = 36,00,000 Joules or $3.6 \times 10^6 \text{ J}$

Question 6.

What is meant by resistance of a conductor? Name and define its SI unit. List the

factors on which the resistance of a conductor depends. How is the resistance of a wire affected if – (i) its length is doubled, (ii) its radius is doubled? (2014)

Answer:

The property of a conductor due to which it tends to stop the flow of current through the conductor is called resistance.

SI unit is ohm. When a potential difference of 1V across a wire gives rise to 1A current through the wire, then the resistance, is said to be 1 ohm (1Ω).

The resistance of conductor depends on length, thickness, nature of material and temperature of conductor.

(i) If length is doubled, then R is doubled because the resistance of a conductor is directly proportional to length.

(ii) Resistance of a conductor is inversely proportional to the square of its diameter or area of cross-section.

This shows $R \propto \frac{1}{A}$, $A = \pi r^2$

If $r' = 2r$ then $A' = \pi r'^2 = \pi(2r)^2 = 4\pi r^2 = 4A$

R = Resistance, L = Length, A = Area, ρ = Resistivity

$R = \rho L / A$

If $A' = 4A$, then

$$R' = \rho \frac{L}{A'} = \rho \frac{L}{4A} = \frac{1}{4} \left(\rho \frac{L}{A} \right) = \frac{1}{4} R$$

Therefore, if radius is doubled, the resistance becomes 1/4.

Question 7.

(i) Establish a relationship to determine the equivalent resistance R of a combination of three resistors having resistances R_1 , R_2 and R_3 connected in parallel.

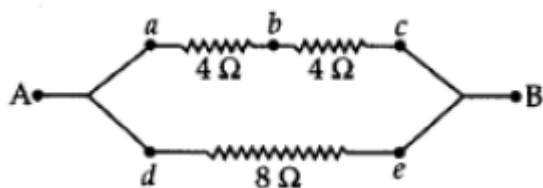

(ii) Three resistors are connected in an electrical circuit as shown. Calculate the resistance between A and B. (2014)

Answer:

(i) Three resistances R_1 , R_2 and R_3 are connected in parallel to one another between the same two points. In this case the potential difference across the ends of all the resistances will be the same.

$$V = V_1 = V_2 = V_3$$

If the total current flowing through the circuit is I, then the current passing through R_1 will be I_1 , R_2 will be I_2 and R_3 will be I_3 .



Then $I = I_1 + I_2 + I_3$

$$I_1 = \frac{V}{R_1},$$

$$I_2 = \frac{V}{R_2},$$

$$I_3 = \frac{V}{R_3}$$

$$I = \frac{V}{R}$$

\Rightarrow

$$\frac{V}{R} = \frac{V}{R_1} + \frac{V}{R_2} + \frac{V}{R_3}$$

$$\frac{V}{R} = V \left[\frac{1}{R_1} + \frac{1}{R_2} + \frac{1}{R_3} \right]$$

\Rightarrow

$$\frac{1}{R} = \frac{1}{R_1} + \frac{1}{R_2} + \frac{1}{R_3}$$

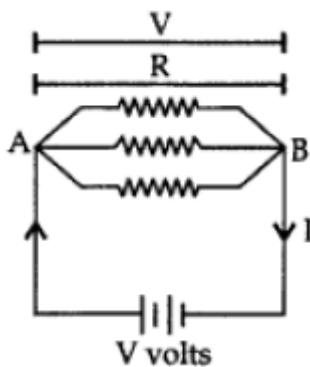

(ii) Resultant resistance between A and B = $R = ?$

$$R_1 = 4 \Omega, R_2 = 4 \Omega, R_3 = 8 \Omega$$

Resultant resistance between a and c = R'

$$R' = R_1 + R_2 \text{ [series combination]}$$

$$R' = 4 + 4 = 8$$

$$\frac{1}{R} = \frac{1}{R'} + \frac{1}{R_3}$$

...[R' and R_3 are in parallel combination]

$$\frac{1}{R} = \frac{1}{8} + \frac{1}{8} = \frac{2}{8} \quad \Rightarrow \quad R = 4\Omega$$

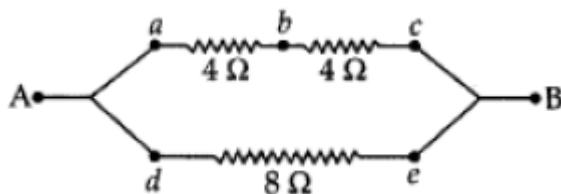

Question 8.

What does an electric circuit mean? Name a device that helps to maintain a potential difference across a conductor in a circuit. When do we say that the potential difference across a conductor is 1 volt? Calculate the amount of work done in shifting a charge of 2 coulombs from a point A to B having potentials +10V and -5V respectively. (2014)

Answer:



- A continuous conducting path consisting of wires and other resistances (like electric bulb, etc.) and a switch, between the two terminals of a cell or a battery along which an electric current flows, is called an electric circuit.
- Battery (or cell) helps to maintain a potential difference across a conductor in a circuit.
- The potential difference between two points is said to be 1 volt if 1 joule of work is done in moving 1 coulomb of electric charge from one point to the other.

Work done, $W = ?$, Charge, $Q = 2C$

Potential at A = +10 V, Potential at B = -5V

Potential difference, $(V) = +10 - (-5) = 10 + 5 = 15$ volts

$V = W / Q \Rightarrow 15 = W / 2$

$W = 15 \times 2 = 30$ J

Question 9.

Name an instrument that measures potential difference between two points in a circuit.

Define the unit of potential difference in terms of SI unit of charge and work. Draw the circuit symbols for a (i) variable resistor, (ii) a plug key which is closed one.

(2014)

Two electric circuits I and II are shown below

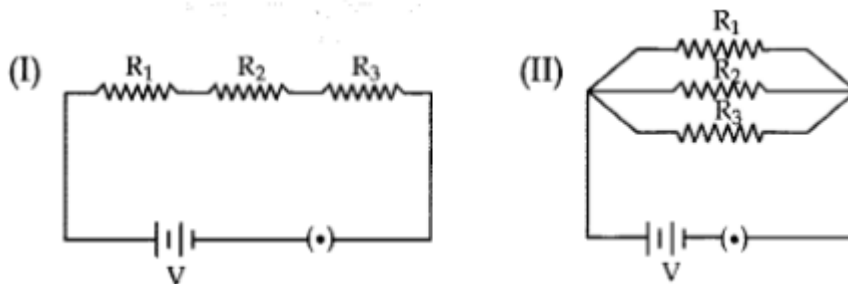

- Which of the two circuits has more resistance?
- Through which circuit more current passes?
- In which circuit, the potential difference across each resistor is equal?
- If $R_1 > R_2 > R_3$, in which circuit more heat will be produced in R_1 as compared to other two resistors?

Answer:



Voltmeter measures potential difference between two points in a circuit. $V = W / Q$



$V =$ Potential difference, $W =$ Work done, $Q =$ Quantity of charge

$V = 1J / 1C = 1$ volt. The SI unit of potential difference is volt.

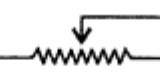
The potential difference between two points is said to be 1 volt if 1 joule of work is done in moving 1 coulomb of electric charge from one point to the other.

Circuit symbols of

(a) variable resistor  or 

(b) a key plug which is closed  or 



- (i) Circuit (I) has more resistance as the combined resistance of any number of resistances connected in series is equal to the sum of the individual resistances.
- (ii) Circuit (II).
- (iii) In circuit (II) the potential difference across each resistor is equal.
- (iv) If $R_1 > R_2 > R_3$ in circuit (I) more heat will be produced in R_1 as compared to other two resistors.

Question 10.

- (a) Describe in brief any three important features of domestic electric supply lines.
- (b) List two distinguishing features between overloading and short circuiting in domestic circuits. (2014)

Answer:

(a) Features of domestic electric supply lines:

(i) From the electric pole two insulated wires come to our houses. One of these wires is called live wire (L) having high potential of 220 V whereas the other wire is called neutral wire (N) having zero potential. Thus the potential difference between these two wires in India is $220 - 0 = 220$ V. The live wire has red insulation covering where as neutral wire has black insulation covering.

(ii) The two wires coming out of the meter are connected to a main switch which is placed in a distribution box. It is used to switch off the electric supply when required so as to repair any faults in the internal wiring.

(iii) All the electrical appliances like bulbs, fans and sockets, etc. are connected in parallel across the live wire and the neutral wire because if one of the appliances is switched off or gets fused, there is no effect on the other appliances and they keep on operating.

(b) Difference features between Overloading and Short-circuiting in Domestic circuits
Overloading:

- If too many electrical appliances of high power rating are switched on at the same time, they draw an extremely large current from the circuit causing overloading.
- Due to an extremely large current flowing through the circuit, the copper wire of the household wiring gets heated to a very high temperature and a fire may start.

Short-circuiting:

- The touching of naked live wire and neutral wire directly causes short circuiting.



- In this case, the resistance of the circuit so formed is very small, thus a large amount of current flows through the circuit and heats the wires to a high temperature and a fire may start.

Question 11.

For the series combination of three resistors establish the relation:

$$R = R_1 + R_2 + R_3$$

where the symbols have their usual meanings.

Calculate the equivalent resistance of the combination of three resistors of 6Ω , 9Ω and 18Ω joined in parallel. (2015)

Answer:

Same current (I) flows through different resistances, when these are joined in series, as shown in the figure.

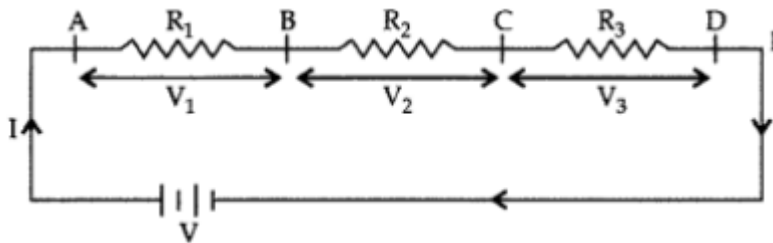

Let R be the combined resistance then, $V = IR$

$$V_1 = IR_1, V_2 = IR_2, V_3 = IR_3$$

$$\therefore V = V_1 + V_2 + V_3$$

$$\therefore IR = IR_1 + IR_2 + IR_3 \Rightarrow IR = I(R_1 + R_2 + R_3)$$

$$\therefore R = R_1 + R_2 + R_3$$

Now, $R_1 = 6 \Omega$; $R_2 = 9 \Omega$; $R_3 = 18 \Omega$

In parallel combination

$$\frac{1}{R} = \frac{1}{R_1} + \frac{1}{R_2} + \frac{1}{R_3} \Rightarrow \frac{1}{R} = \frac{1}{6} + \frac{1}{9} + \frac{1}{18} = \frac{3+2+1}{18} = \frac{6}{18} = \frac{1}{3}$$

$$\therefore \frac{1}{R} = \frac{1}{3} \Rightarrow R = 3\Omega$$

Question 12.

Study the following current-time graphs from two different sources:

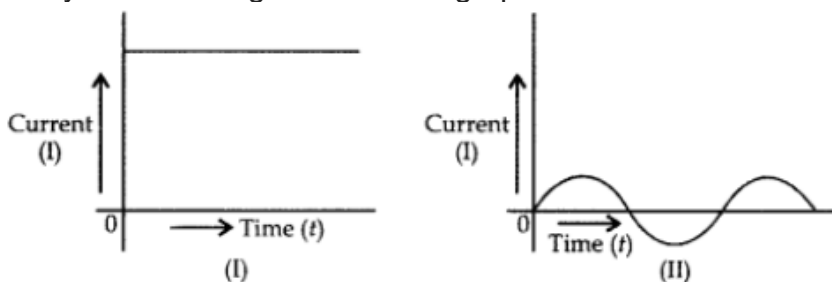

- Use above graphs to list two differences between the current in the two cases.
- Name the type of current in the two cases.

(iii) Identify one source each for these currents.

(iv) What is meant by the statement that “the frequency of current in India is 50 Hz”?

Answer:

(a)

I	II
1. (I) shows Direct Current (D.C.).	1. (II) shows Alternating Current (A.C.).
2. The Current (I) flows in one direction only. It is called a direct current. The magnitude and direction of flow of current remains the same.	2. The current (II) reverses direction after equal intervals of time. It is called alternating current. The magnitude and direction of current change continuously at definite intervals of time.
3. The magnitude of current in (I) does not become zero with the Passage of time.	3. The magnitude of (II) becomes zero after a regular time interval.

(ii) (I) (D.C.) – Direct Current; (II) (A.C.) – Alternating Current

(iii) Source of D.C. → a cell, battery, solar cell, D.C. generator

Source of A.C. → A.C. generator.

(iv) ‘The frequency of current in India is 50 Hz’ means the direction of current in India changes 100 times in 1 second as current direction changes twice in one cycle.

Question 13.

What is meant by electric circuit? Why does electric current start flowing in a circuit the moment circuit is complete? When do we say that the potential difference across a conductor in a circuit is 1 volt? Calculate the potential difference between the two terminals of a battery if 12 joules of work is done in transferring 2 coulombs of charge. (2015)

Answer:

A continuous conducting path consisting of wires and other resistances (like electric bulb, etc.) and a switch, between the two terminals of a cell or a battery along which an electric current flows is called an electric circuit.



It is the potential difference between the ends of the wire which makes the electric charges (or current) flow in the wire.

The potential difference between two points is said to be 1 volt if 1 joule of work is done in moving 1 coulomb of electric charge from one point to another.

$$\text{Thus, 1 volt} = \frac{1 \text{ joule}}{1 \text{ coulomb}}$$

$$\text{or } 1 \text{ volt} = \frac{1\text{J}}{1\text{C}} \text{ or } 1 \text{ JC}$$

$$V = ?$$

$$W = 12 \text{ J}$$

$$Q = 2\text{C}$$

$$\text{Now, } V = \frac{W}{Q} = \frac{12\text{J}}{2\text{C}} = 6 \text{ volts}$$

Question 14. State Ohm's law. Draw a labelled circuit diagram to verify this law in the laboratory. If you draw a graph between the potential difference and current flowing through a metallic conductor, what kind of curve will you get? Explain how would you use this graph to determine the resistance of the conductor. (2015)

Answer:

Ohm's law states that the electric current, through a conductor, is directly proportional to the potential difference across its two ends when, other physical conditions like temperature, etc., remain constant.

$$V \propto I \text{ or } V/I = \text{Constant} = R \text{ or } V = IR$$

Thus, the ratio $V : I$ is a constant. This constant is called the resistance (R) of the conductor.

Circuit diagram for Ohm's law:

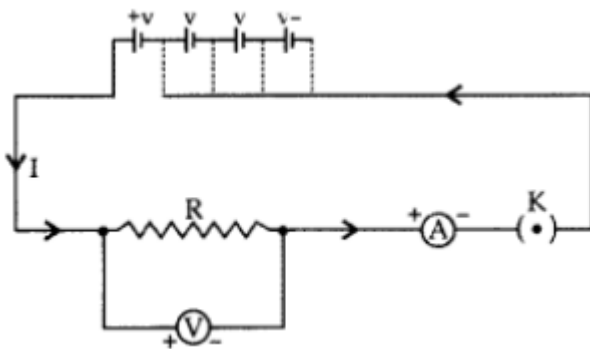

Explanation. If a graph is drawn between the potential difference (V) and current (I), the graph is found to be a straight line passing through the origin. This shows current is directly proportional to the potential difference. Thus the ratio V/I remains constant. This constant is called the resistance of the conductor. The gradient of the straight line graph is related to the resistance (R) of the conductor.



Graph:

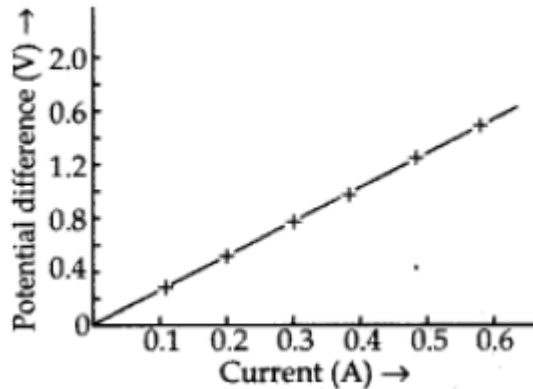

Question 15.

When an electric current flows through a conductor it becomes hot. Why? List the factor on which the heat produced in a conductor depends. State Joule's law of heating. How will the heat produced in an electric circuit be affected, if the resistance in the circuit is doubled for the same current? (2015)

Answer:

When an electric current is passed through a conductor it becomes hot. This is called heating effect of current. The heating effect of current is obtained by the transformation of electrical energy into heat energy. A battery or a cell is a source of electrical energy. The chemical reaction within the cell generates the potential difference between its two terminals that sets the electrons in motion to make the current flow through a resistor. The source has to keep expending its energy. A part of the source energy in maintaining the current may be consumed into useful work and rest of the source energy may be expended in heat.

The heat produced in a wire is directly proportional to

- (i) square of current (I^2).
- (ii) resistance of wire (R).
- (iii) time (t), for which current is passed.

Joule's Law of heating states that when a current of T amperes flows in a wire of resistance ' R ' ohms for time ' t ' seconds, then the heat produced in the conductor is equal to the product of the square of the current. Joule's Law of heating gives the formula

$$H = I^2 \times R \times t$$

Since, $H \propto R$,

therefore if the resistance in the circuit is doubled then heat produced will also get doubled.